

ComNav Marine Autopilots

#15 - 13511 Crestwood Place  
Richmond, BC  
Canada V6V 2G1  
Phone: 604-207-1600  
Fax: 604-207-8008

In Canada or the USA  
Toll Free Phone 1-800-428-0212  
Toll Free Fax 1-800-470-9611  
E-Mail: [sales@comnav.com](mailto:sales@comnav.com)  
Web Site: <http://www.comnavmarine.com>

---

## **18CI & 30CI Adjustable Reversing Motor Pump**

Owner's Manual

Part Numbers: 20810016, 20810018, 20810031 & 20810035

Manual Part Number: 29010016

Revised: October 6, 2004

**\*\*\*\*\* IMPORTANT \*\*\*\*\***

The reversing motor pump you have purchased is a reliable, high quality product that will give you many years of trouble-free service. To ensure that you get the most from your purchase, read this installation and instruction manual carefully. By following the step-by-step procedure and using only basic tools and materials, you will find the installation easy to do.

**This Pump is not watertight and therefore is not covered under warranty against water damage.**

**If you are installing this pump on a Capilano or Syten steering system, you probably have a 3 line steering system. Read the 3 line steering installation instructions carefully.**

**TOOLS AND MATERIAL REQUIRED TO INSTALL PUMP**

1. Basic Tool Kit
2. Pipe Cutter
3. Funnel with Filter (a coffee filter will do)
4. 3/8" Electrical Drill
5. 2 Gallon Bucket (to catch excess oil)
6. Rags or Paper Towels
- \*7. Pipe Fittings (**check with steering gear manufacturer for type and size**)
- \*8. Tubing (**check with steering gear manufacturer for type and size**)
9. Hydraulic Oil (**check with steering gear manufacturer for type**)
10. Teflon Based Thread Sealer (such as LOCKTITE P.S.T.)
11. Miscellaneous Hardware (for mounting pump and securing lines)

**\*Consult with your steering system manufacturer to get detailed information regarding factory authorized installation materials. Failure to do so could void your warrantee.**

## 18CI AND 30CI ADJUSTABLE REVERSING DC MOTOR PUMP

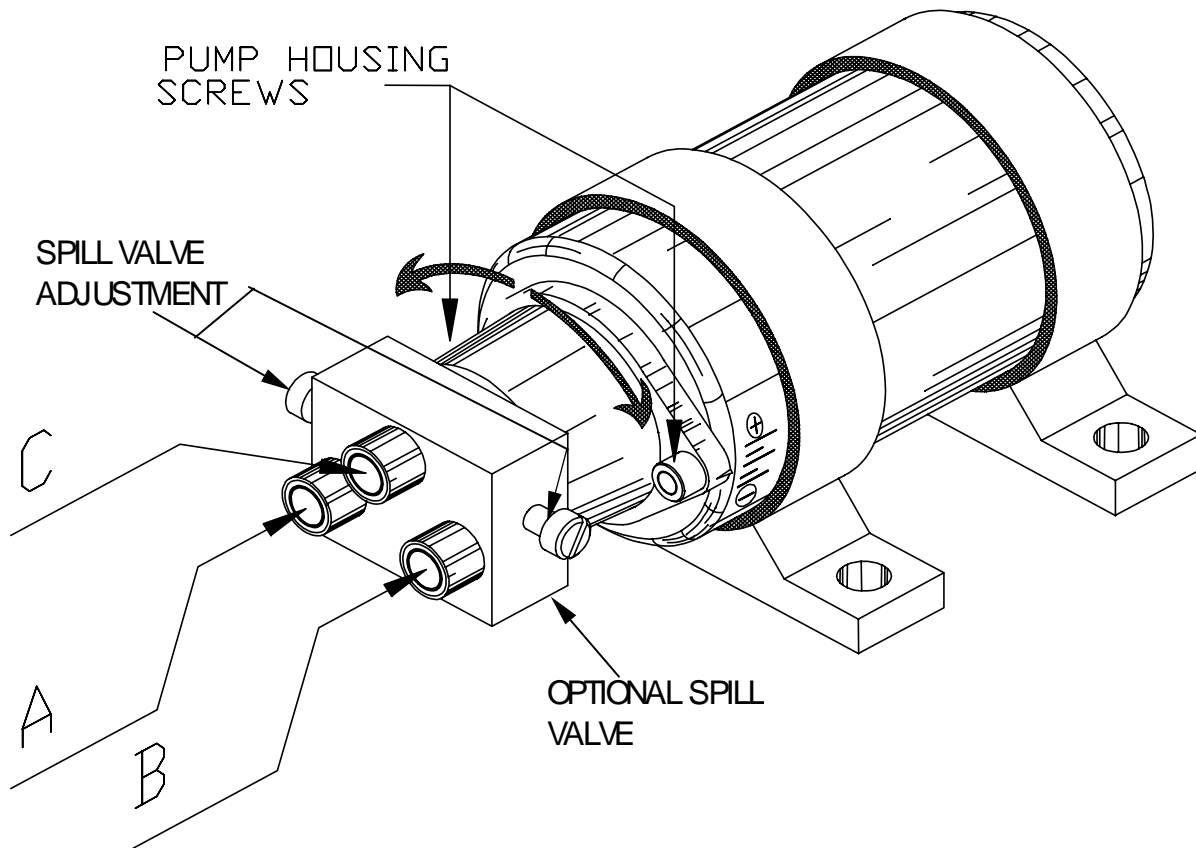

To adjust flow rates simply loosen the pump housing screws a small amount and turn the pump housing. Turning the housing clockwise will decrease flow rate and anti-clockwise will increase flow rate.

## PLANNING

Installation of the pump consists of:

- Finding a mounting location for the pump.
- Partially draining the steering system.
- Mounting and connecting the pump to the existing steering lines.
- Filling and bleeding the steering system.

A suitable mounting location for the pump MUST:

- Be dry
- Be lower than at least one of the helm pumps in the steering system.
- Provide a solid mounting base.
- Be at least 6 feet (2 meters) from the vessel's compass.

A mounting location for the pump SHOULD:

- Provide easy access to the pump.
- Provide an easy connection point to the steering system.
- Minimize the length of the pump hoses.
- Minimize the length of the wires to the motor.

A typical mounting location would be in the engine compartment or the steering console.

The pump can be mounted in any orientation except with Port C facing downward. If Port C is facing downward then air will not be able to rise out of the pump and the pump will not have a supply of oil.

There are two ways to connect the pump to

the steering system. The first is to leave the system completely filled and be careful not to spill hydraulic fluid. The second is to drain the system of fluid completely before cutting or opening any lines.

If you follow the first method, remember that when you disconnect or cut the steering lines, there will be a constant slow discharge of oil due to gravity draining the system. Have a container ready to catch all excess oil. Do not reuse any oil reclaimed from your system.

### Draining your System

If you wish to follow the second method and drain the system, use the following simple procedure.

1. Have a large container, about 2 gallons, ready.
2. Disconnect the delivery lines at a low point, usually where the lines connect to the steering cylinder.
3. Turn the wheel of the highest helm pump in both directions until no more fluid comes out of the lines.
4. Repeat the previous step on each lower helm pump in turn.

### Types of Steering Systems

There are two general types of steering systems, two line systems, and three line systems. The pump connection to the steering system is different for each type. Separate instructions are supplied for both types of steering systems.

You have a three-line system if the helm pump is a Capilano Model 250 or 275 (Made by Teleflex), or there is a Uniflow valve mounted close to the steering cylinder.

You have a two-line system if you do not have the above components in your system.

### **CAUTION**

*CLEANLINESS must be maintained while making hydraulic connections. Contamination introduced into the steering system fluid can cause steering components to malfunction, possibly resulting in a loss of steering.*

Before beginning to connect the pump to the steering system, review the following installation hints:

- Cap or cover the ends of hoses with a clean rag before pushing them between bulkheads.
- Do not blow copper filings off freshly cut and reamed copper tube. Wipe the filings off instead
- Do not use a tape type thread sealer. These can shred and enter the steering system fluid. A Teflon based thread sealer, such as 'LOCTITE P.S.T.' must be used on all male pipe threads. Do not place thread sealer on the first two threads.
- Do not place thread sealer on female pipe threads.
- When tightening fittings into the pump lockvalve, hold the lockvalve, not the motor. That way, the lockvalve will not twist out of alignment with the rest of the pump.
- Connection of the pump lines is most easily made at existing breaks in the steering system lines. For example: valves, t-joints and other fittings.

Opening your hydraulic steering system will allow air to enter the pipes and pumps. This air must be expelled when the steering system is bled after you refill your system and during the "Set-up Routine" when you can use the Autopilot to expel it.

## HYDRAULIC CONNECTIONS FOR TWO LINE STEERING SYSTEMS

A simple schematic of the pump installation is shown in Figure 2.

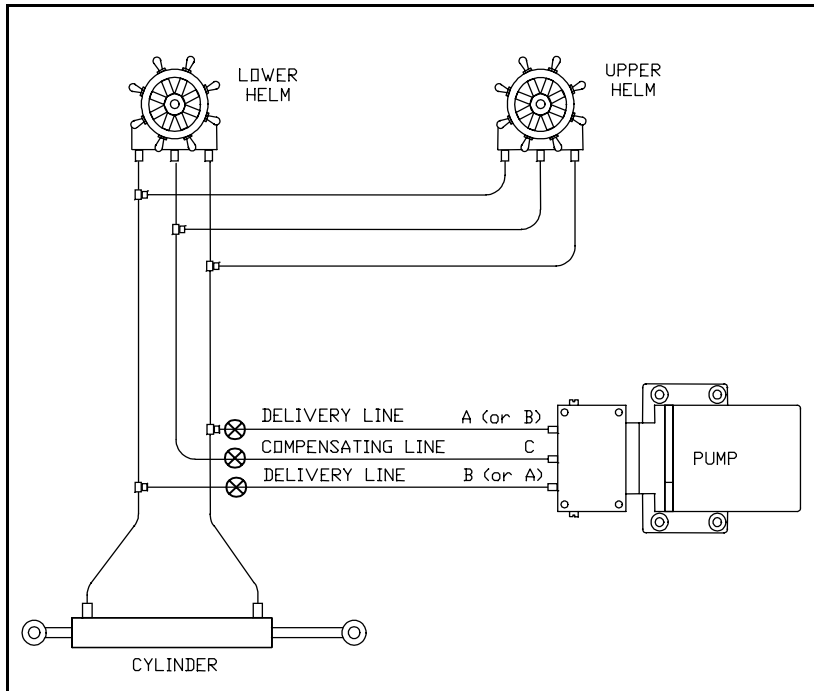

**2 Line Steering System Installation**

### Delivery Lines:

Ports A and B in the diagram above are the input/output ports of the pump and must be connected to the steering lines coming from the steering cylinder. It does not matter which pump port is connected to which steering line.

### Compensating Line:

In the above diagram Port C is the compensating or bleed line, and must be connected to the steering system's reservoir. This connection can be made at a helm pump, remote reservoir (if there is one), the compensating line connecting two helm pumps, or the compensating line connecting a helm pump to the remote reservoir. If the connection is being made directly to the helm pump, ensure that the bleed line is connected to the **LOWER** helm bleed port. The compensating line **MUST** have a gradual rise from the pump to the connection to the steering system. This allows air to rise out of the pump, ensuring a constant supply of oil to the pump.

# HYDRAULIC CONNECTIONS FOR THREE LINE STEERING SYSTEMS

A simple schematic of the pump installation is shown in Figure 3.

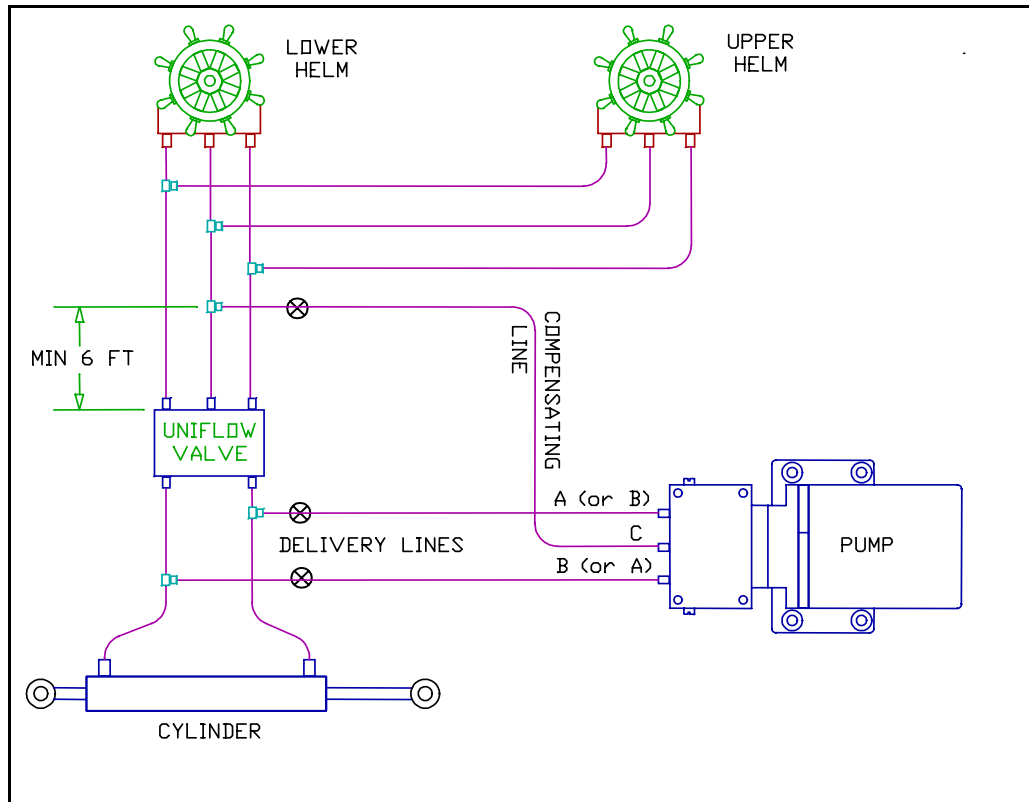

## Delivery Lines:

In the above diagram, Ports A and B are the input/output ports of the pump and must be connected to the steering lines between the steering cylinder and the Uniflow valve. The simplest method of doing this is to install a tee in each of the cylinder ports of the uniflow valve itself and connect to these tees. It does not matter which pump port is connected to which steering line.

## Compensating Line:

Port C is the compensating or bleed line and must be connected to the steering system's reservoir. This connection can be made at: a helm pump; a remote reservoir (if there is one); the return line connecting two helm pumps; or the return line between a pump and the Uniflow valve. If the connection is being made directly to the helm pump, ensure that the bleed line is connected to the **LOWER** helm bleed port.

The connection **MUST** be at least six feet (2 M) from the Uniflow valve as shown above. If the connection is too close to the Uniflow valve, the manual steering system may not work well.

The compensating line **MUST** have a gradual rise from the pump to the connection to the steering system. This allows air to rise out of the pump, ensuring a constant supply of oil to the pump.

## REFILL AND BLEED

After you have installed your pump, refill and bleed your manual steering system according to the manufacturer's directions. Any air, which is in the pump, will be expelled in a separate bleeding routine after you connect the Pump to the autopilot.

### TECHNICAL SPECIFICATIONS

Part Number:	20810016	20810018	20810031	20810035
Model Number:	18CI	18CI	30CI	30CI
Operating Voltage:	12VDC	24VDC	12VDC	24VDC
Max Displacement @ 200PSI:	73 in <sup>3</sup>	73 in <sup>3</sup>	122 in <sup>3</sup>	122 in <sup>3</sup>
Current @ 200 PSI:	4.5 Amps	3.0 Amps	6.0 Amps	3.0 Amps
Max Pressure:	800 PSI	800 PSI	500PSI	500PSI

### ALL PUMPS

Port Sizes:	- 3/8 inch compression fittings supplied
Displacement (18CI):	- Adjustable, from 36in <sup>3</sup> (600cm <sup>3</sup> ) to 73in <sup>3</sup> (1200cm <sup>3</sup> )
Displacement (30CI):	- Adjustable, from 61in <sup>3</sup> (1000cm <sup>3</sup> ) to 122in <sup>3</sup> (2000cm <sup>3</sup> )
Min Stall Pressure:	- 1200 PSI (84.0 Bar) (8,268 kPa)
Oil Type:	- Any approved hydraulic steering fluid
Operating Temperature:	- 0 to 50 Degrees Celsius (32 to 122 Fahrenheit)
Lockvalve:	- Yes
Lockvalve Leakage:	- Negligible
Unbalanced Cylinder:	- Yes, up to 3/4 (1.9cm) diameter rod
Weight:	- 5.0 lbs (2.27 kg) including wire
Size:	- 10 inches x 3.75 inches x 4.75 inches
Size (metric):	- 254mm x 95mm x 121mm
Shaft Seal:	- 100 PSI (6.89 Bar) (689 kPa) minimum

# 18CI & 30CI ELECTRICAL CONNECTIONS

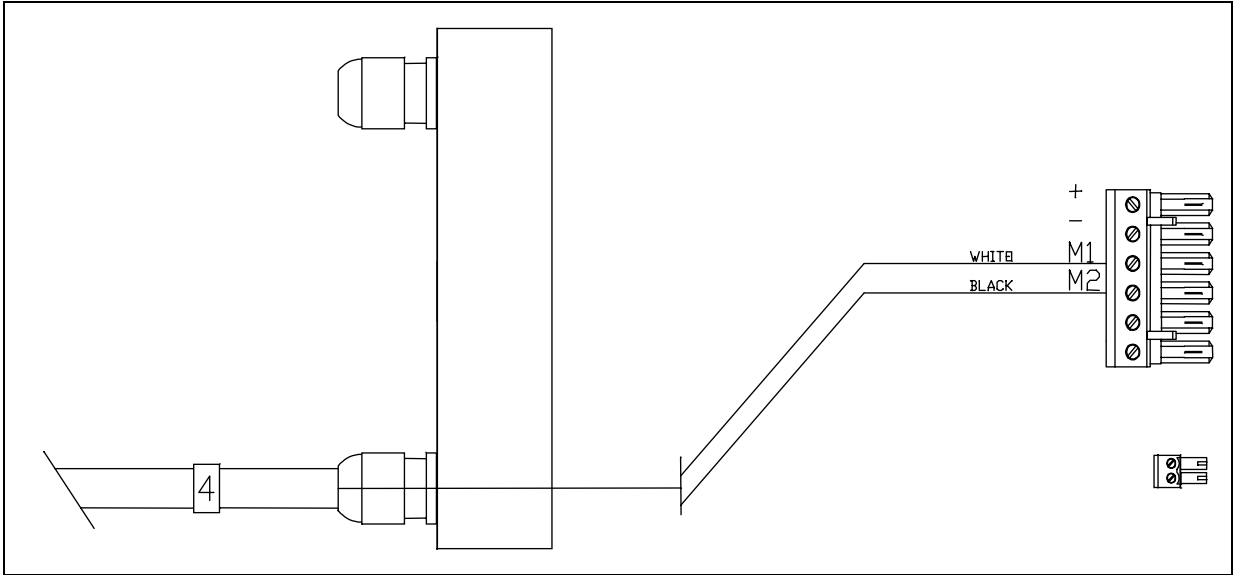

The drawing above shows how to connect the two wires from the 18CI and 30CI pump to the various motor drive controller units. The electrical connections shown apply to several ComNav products. These products are as follows:

- 1) ComNav CT2 (part #20350001) Reversing DC Motor Drive Box - 1001 & 2001 Autopilots
- 2) ComNav 1420 Processor (part #20070003) - 1420 Autopilots
- 3) ComNav 1440 Processor (part #20080003) - 1440 Autopilots (Not available in North America)

## PUMP BLEEDING INSTRUCTIONS

1. Bleed your manual steering system according to the manufacturer's instructions. When you have completed the bleeding, leave the equipment for the bleeding procedure attached to your hydraulic steering system.
2. Fill your highest reservoir completely. Turn the steering wheel just past the stop to press as much oil as is possible into the system.
3. If you can, use a bottle of recommended hydraulic oil and a piece of plastic tubing to add extra capacity to your highest reservoir.

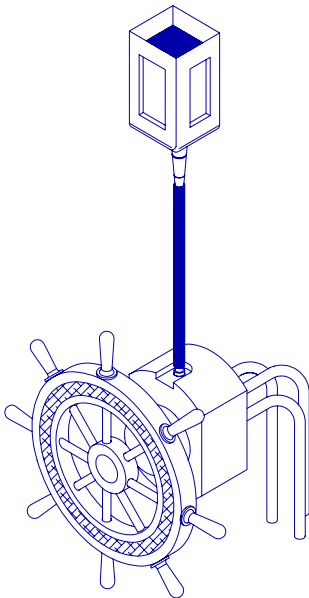

**Adding Capacity**

The manufacturer of your system may provide these items when you purchase a bleeding kit for your system. If you have a helper, have them watch the oil level in the highest reservoir and refill it when necessary.

4. Your hydraulic cylinder rod is now fully extended in one direction. To bleed the Reversing Pump you will be extending the cylinder rod in the other direction. Open one and close the other bleeding screw just as you did when bleeding the manual part of your system and you were extending the cylinder arm in this direction. Generally, you close the bleeding screw or nipple closest to the rod which is now retracted. Open the bleeding screw closest to the now extended rod. See diagram on following page.
5. If possible, position yourself so that you can see your hydraulic steering cylinder while operating the steering controls of the autopilot.
6. You will be able to move the steering cylinder rod by pressing the Red Key or the Green Key on the Autopilot. When you press the key, the lights will stop blinking and the red or green light will turn on. Extend the rod as far as it will travel in the other direction.
7. The Autopilot will stop driving the Reversing Pump shortly after the rod reaches the end of its travel.

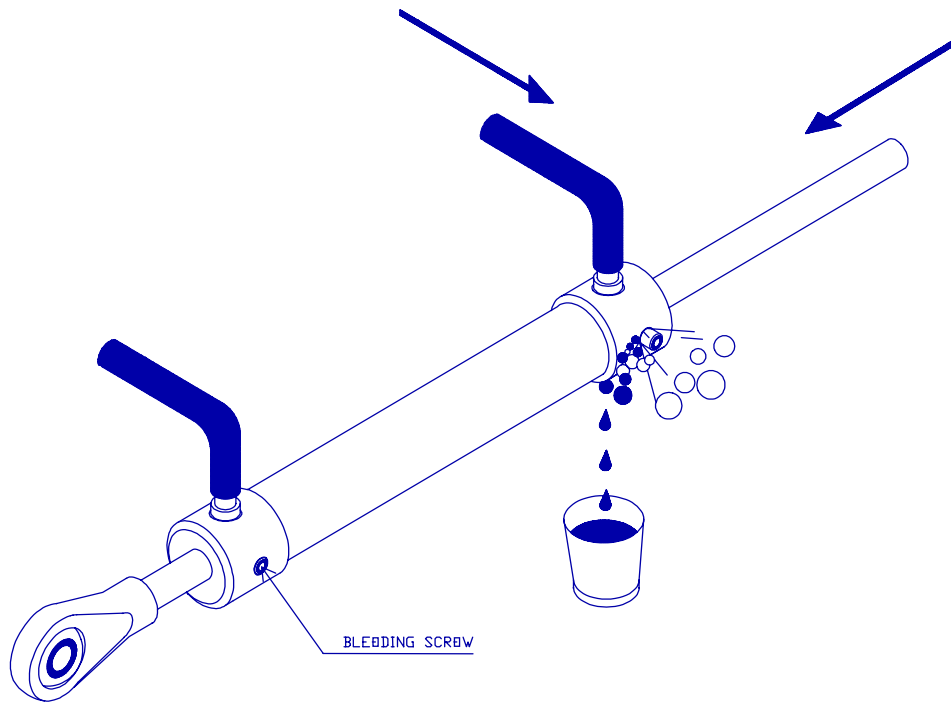

Bleeding cylinder, rod moving left

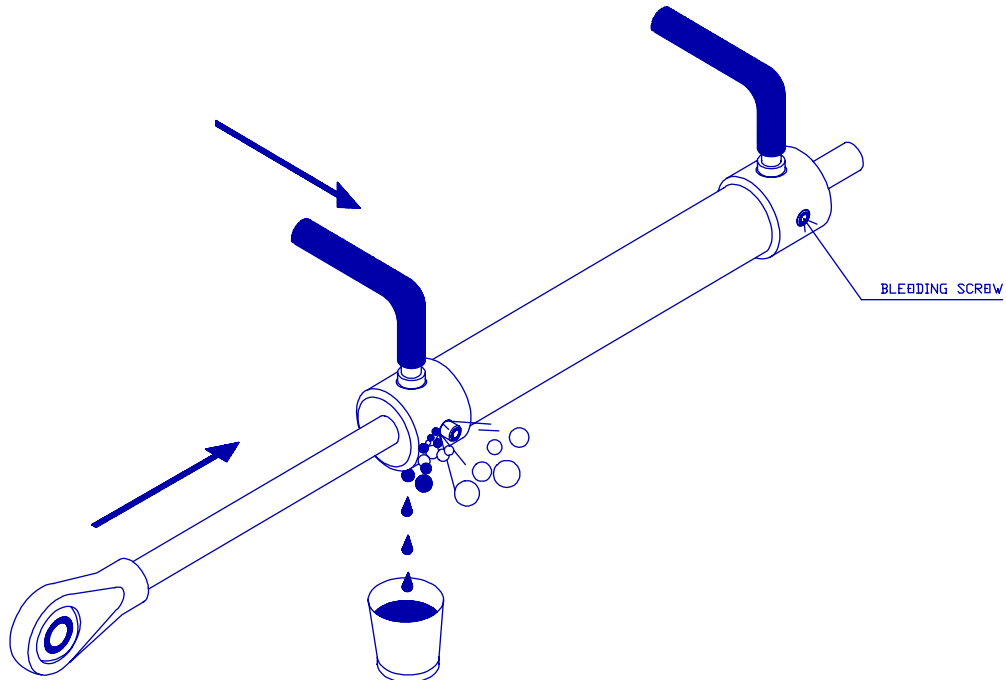

Bleeding cylinder, rod moving right.

8. Refill your steering system from the highest reservoir.
9. Adjust the bleeding screws so that the cylinder will be bled when the rod is extended in the original direction. Generally, you close the bleeding screw or nipple closest to the now retracted rod. Open the bleeding screw closest to the rod which is now extended.
10. Use the Autopilot to fully extend the cylinder rod to the other side.
11. Refill the highest reservoir.
12. Repeat steps 6 to 10 at least 10 times.
13. Close all bleeding screw or nipples. Clean up any spills of oil and wipe fittings clean. Remove any buckets or equipment a short distance from the cylinders and fittings.
14. Use the Autopilot to extend the rod fully in one direction and then the other.
15. Check for leaks by looking for spilled hydraulic fluid near or on fittings and cylinders.

---

**\*\*\*\* IMPORTANT \*\*\*\***

If you have installed a ComNav Marine reversing motor pump, a constant running pump or an engine driven pump, there are several checks that must be done during the first several weeks of usage in order to prevent poor or dangerous steering performance.

***Proper hydraulic pump speed***

After you have filled and bled your hydraulic steering system and drive unit, it is important to check that your drive unit can attain a hardover to hardover time of 10 to 15 seconds. This is the optimum speed for proper autopilot operation.

***Residual air in your steering system***

Following the initial installation and bleeding of your ComNav pump, some residual air may remain suspended in the hydraulic fluid. During the first few weeks, this air will gradually bleed out through the header tank or the highest helm pump and the oil level may go down. Check several times and add more oil as required.

***Leaking fittings or equipment***

Following the initial installation and bleeding of your ComNav pump continuously monitor the oil level of the reservoir or the highest helm pump in your steering system and add oil as required. If this condition persists, it may be an indication of leakage in your steering system. Check all hydraulic steering fittings and equipment for leakage.

## MANUAL CHANGES

DECEMBER 31, 1996

1. PAGE 11 - A STERNER, MORE DETAILED WARNING WAS GIVEN REGARDING RESIDUAL AIR AS WELL LEAKING FITTINGS AND EQUIPMENT.
2. PAGE 11 - WARNING ADDED ABOUT ATTAINING A 10 TO 15 SECOND H.O. TIME.
3. Converted document to Word.

July 5, 1999

Added shut-off valves to hydraulic connection diagrams.

September 26, 2000

REMOVED:

**"ComNav does not recommend the use of reversing motor pumps in most commercial applications or in cases where the average duty cycle will exceed 200 hours per month"**

CHANGED:

Address

October 6, 2004

CHANGED:

To New PartNumber